

Cuerpo / Body	Variante / Variant	Material / Material	Traitamiento / Material treatments	Acabado / Finishes	Cant. / Qty
230285-Nut_M3	00	Acero al caono Carbon steel	-	Zn 8µ min, pas. transparente / RNS:96h Zn plated 8µ min, colourless pas. / NSS:96h	1
230285-Cage	00	C67S EN 10132-4	Templado Austempered	Zn 8µ min, pas. transparente / RNS:96h Zn plated 8µ min, colourless pas. / NSS:96h	1

El proceso de montaje en automático de la pieza requiere previamente la consulta a A.Raymond Tecniacero.
Automatic processing of the part requires prior consultation with A.Raymond Tecniacero.

Condiciones de montaje /
Assembly conditions:

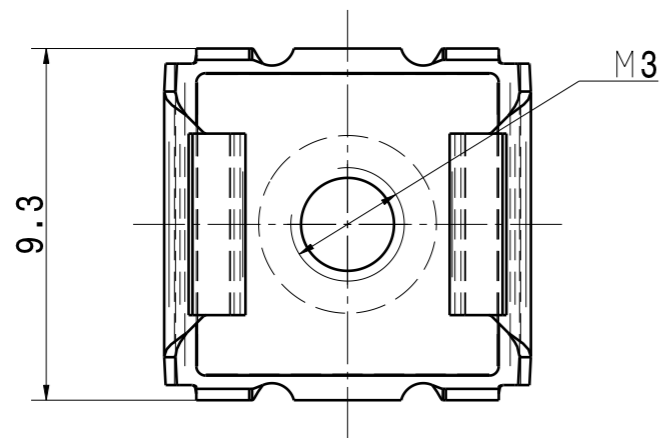
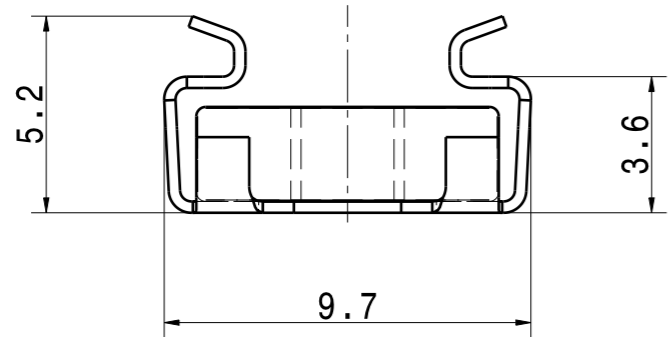
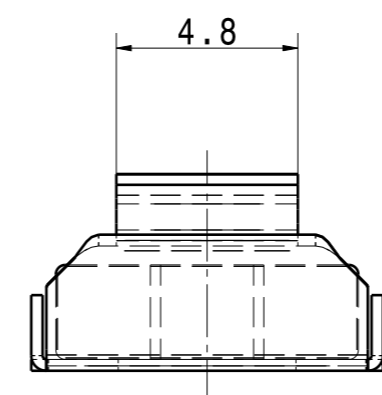
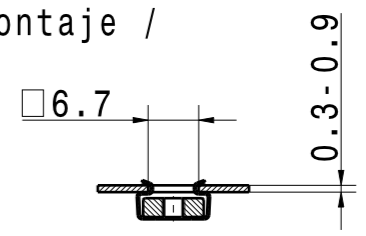

VERIFICAR LA ESCALA DESPUÉS DE LA FOTOCOPIA / BEWARE SCALE AFTER COPY

>400 <= 1000	±2
>120 <= 400	±1.5
> 30 <= 120	±1
> 6 <= 30	±0.5
<= 6	±0.25
Angulo / Angle	±3°

Tolerancias generales para cotas sin especificar.
General tolerances for nominal dimensions without specified tolerances.



Vista isométrica
Isometric view
Escala / Scale: 1:1

REV.	Quant.	Indice / revision description	Date	Name
Eb	1	Corregido espesor material / Material thickness corrected	18.06.13	JGA
Ba	-	Actualizado 3D / 3D updated	17.06.13	JGA
Aa	-	Revisión inicial / Initial release	17.03.13	JGA



Ctra. Manresa a Berga km 0,5
Spain - 08272 Sant Fruitós de Bages
Tel +34 938 771 314
Fax +34 938 770 260

Si tuvieran problemas de comprensión, por favor soliciten la versión española a ARaymond antes de usar este plano.
"CONDITIONS OF USE"
This drawing and all information (the "Drawings") disclosed are the exclusive property of A.Raymond.
By using this Drawing the Addressee acknowledges and accepts that this Drawing (1) is covered by A.Raymond intellectual property rights or know-how and (2) is provided under the following conditions who represent a Deposit Agreement. This Drawing is for Addressee internal use only limited to its estimation. Without prior written consent of A.Raymond, no permission or rights for any purpose, is hereby granted, such as, without any limitation, (1) the copy, in part or entirely (2) and/or the presentation, in part or entirely, to any other third party outside the Addressee company or in the company but with no interest (3) and/or the distribution of the Drawings, in part or entirely, in any medium (4) and/or the creation of any derivative work. In case of breach of these conditions, Addressee shall indemnify A.Raymond from and against all damages (compensatory or consequential), costs, expenses and charges, caused or arising out of or attributable to its willful misconduct, fraud, negligence, infringement of A.Raymond Intellectual Property rights. If the Addressee does not accept these conditions, please notify A.Raymond sender immediately.

Ref. patentes / Patent rights	Código SAFIX / Classification	AI-C-
Nº Proyecto / Project No.	Sustituye / Origin	230285-1-Aa
Resp de proyecto / Project Manager	PADULLES.S	
Escala / scale	Format	Tolerancias generales / General tolerance
5:1	A3	Cf nota Cf nota
Fecha / date	17.03.2013	
Preparado por / Prepared by	GAMISANS.J	
Aprobado / Approved	20130618100538	
Espeor mat. / Mat. thickness	Volumen / volume (mm³)	Peso / Weight (g)
0,30	196	1,5

Acabado / finish
See parts list
Ver dibujo

Tratamiento mat. / Material treatment
See parts list
Ver dibujo

Material / Material
See parts list
Ver dibujo

Denominación / Title
Tuerca métrica enjaulada M3
Metric pitch nut
M3 cage nut

Número / Part no.
230285-0-00

Ref. cliente / Customer part no.
Hoja / Sheet 1/1

CAD system & version CATIA V5 R19 SP9
Nombre fichero / Filename 230285-0C00