

Anzugsdrehmoment max 3.5 Nm

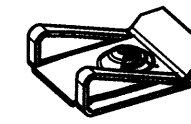

3D-Ansicht  
1:1

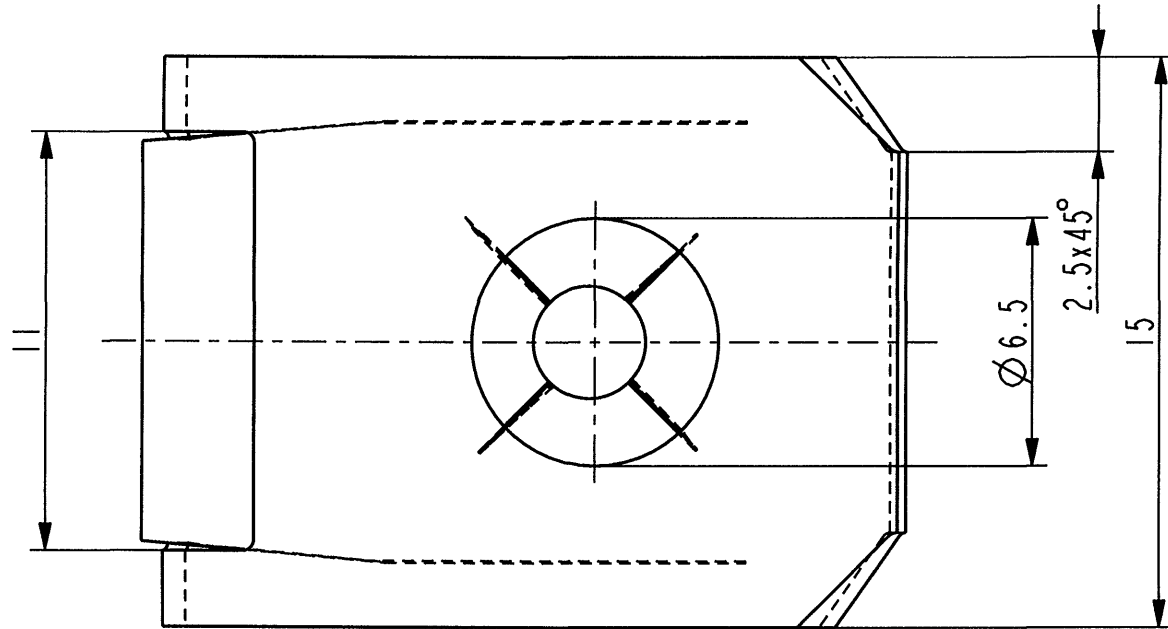
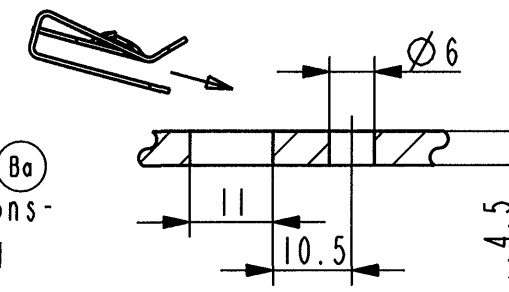

Einbausituation  
1:1

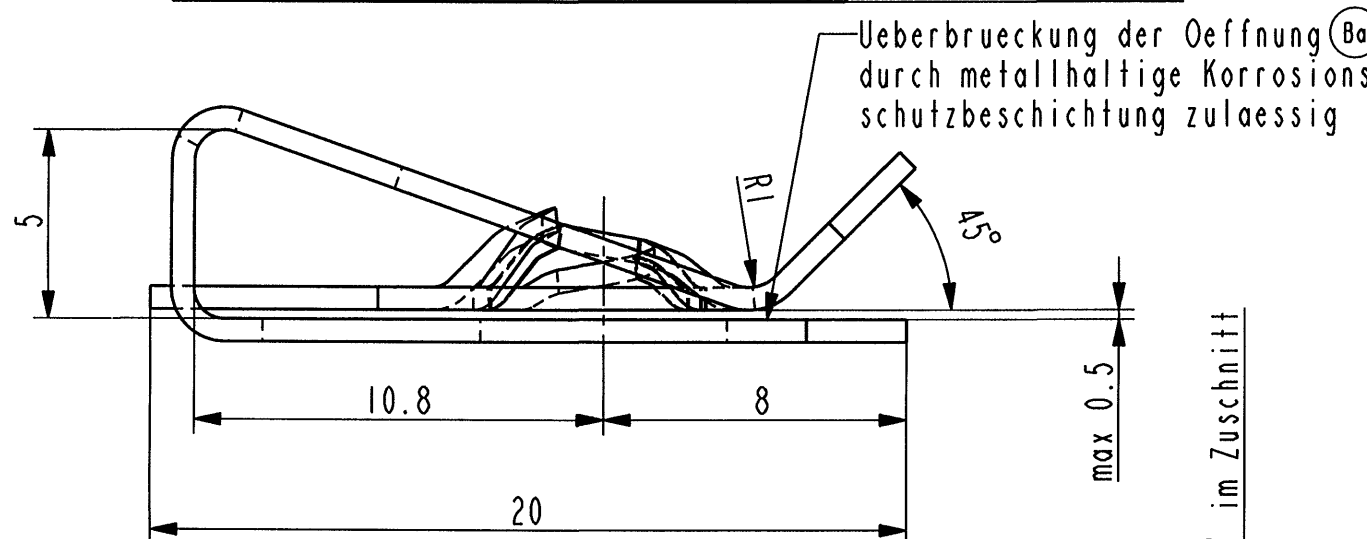

Ueberbrueckung der Oeffnung (Ba) durch metallhaltige Korrosionsschutzbeschichtung zulaessig

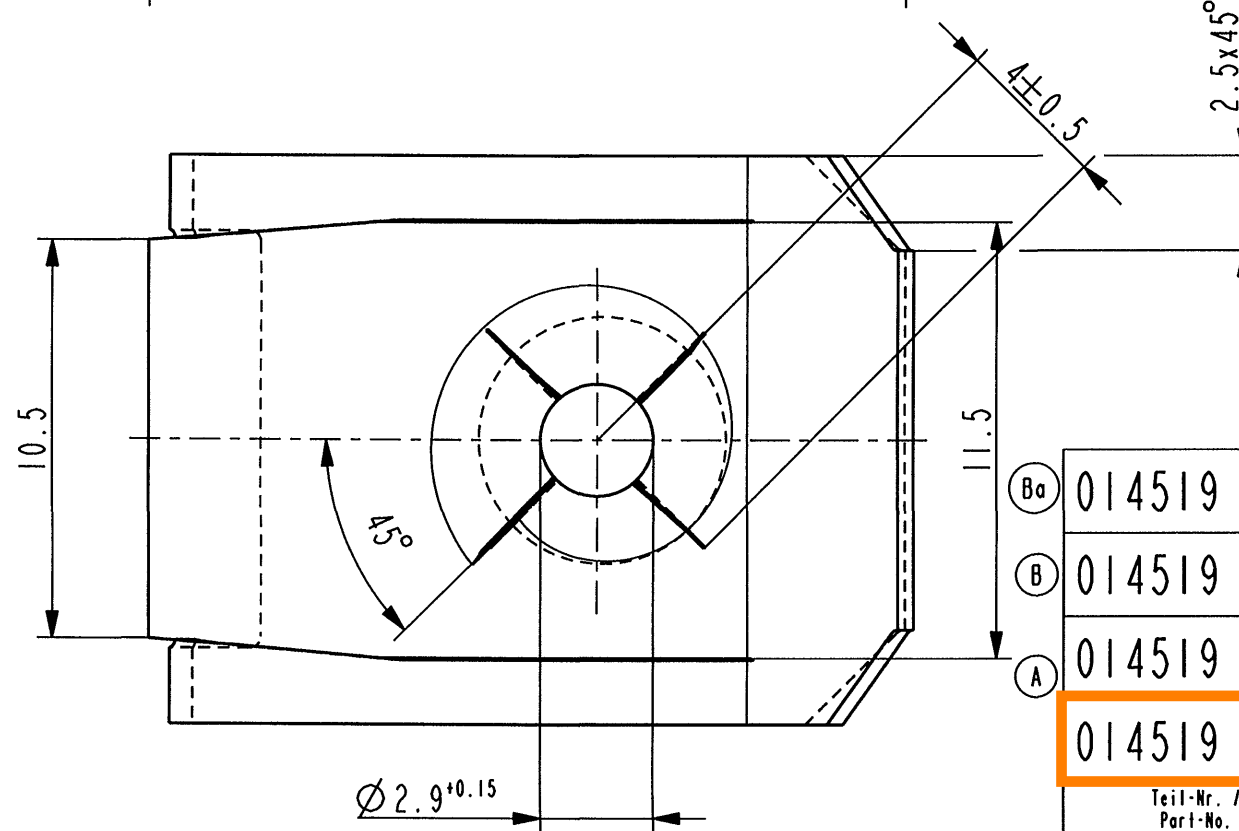

<http://www.cergy-vis.fr>  
**[CERGY-VIS]**  
 ET SI ON PARLAIT SERVICE

Teil-Nr. / Part-No.	Oberflaeche / Farbe / Finish / colour	Kennzahl / Code number
(Ba) 014519 006	metallh. Korrosionsschutzbeschichtung, Farbe silber/GZ	4003
(B) 014519 005	verzinkt/passiviert farblos	3250
(A) 014519 003	metallh. Korrosionsschutzbeschichtung, Farbe silber	5412
014519 002	phosphatiert	5000
Ausfuehrung / Execution		

Vor Auslegung einer automatisierten Verarbeitung des Teils sollte Ruecksprache mit Fa. A.Raymond gehalten werden. Fully automatic processing of the part requires prior consultation with A.Raymond GmbH.

Ind.	kommt vor / how often	Beschreibung / Description	Datum/Date	Name
Ba	2x	Oberflaechenvariante hinzug., Text hinzug.	16.03.06	Ru
B	1x	Oberflaechenvariante hinzugefuegt	28.06.05	mj
A	1x	Indexreform, Art.-Nr. gem. SAP geaend.,	22.12.03	mj
-	-	Oberflaechenvariante hinzugef.	-	-

Aenderungen / Modifications

Format DIN A3  
  
 SPEZIALBEFESTIGUNGSSYSTEME WELTWEIT / ENGINEERED FASTENERS WORLDWIDE

Bei Verstaendnisproblemen beantragen Sie bitte beim Absender die deutsche Fassung vor jeder Anwendung. "CONDITIONS OF USE"  
 This drawing and all information (the "Drawing") disclosed are the exclusive property of A.Raymond. By using this Drawing the Addressee acknowledge and accept that this Drawing (1) is covered by A.Raymond' intellectual property rights or know-how and (2) is provided under the following conditions who represent a Deposit Agreement. This Drawing is for Addressee' internal use only limited to its estimation. Without prior written consent of A.Raymond, no permission or rights for any purpose, is hereby granted, such as, without any limitation, (1) the copy, in part or entirely (2) and/or the presentation, in part or entirely, to any other third party outside the Addressee' company or in the company but with no interest (3) and/or the distribution of the Drawing, in part or entirely, in any medium (4) and/or the creation of any derivative work. In case of breach of these conditions, Addressee shall indemnify A.Raymond from and against all damages (compensatory or consequential), costs, expenses and charges, caused or arising out of or attributable to its willful misconduct, fraud, negligence, infringement of A.Raymond' intellectual property rights. If the Addressee does not accept these conditions, please notify A.Raymond' sender immediately.

Dateiname/ Filename CAD-PE: 014519_C.01			
Ersatz fuer/ Substitute for	14519 Ind.8 v. 18.04.1997	Proj.-Nr./ Proj.-No.	RASCH-Code AAAAD
Schutzrechte/ Patent rights	vorbehalten / all rights reserved		
Gepr./ App.	F.-gepr./ Produktion	O.-gepr./ Quality	S.-gepr./ Patent app.
Masstab / Scale	Allgem.Tol. wenn nicht anders angegeben General tol. unless otherwise specified	Datum/ Date	22.12.2003
	5:1	Gez./ Drawn	M. Junge
Oberflaechenbehandlg./ Finish	verzinkt / gelbchromatiert		Kennzahl/ Code number 3000
Werkstoffbehandlg./ Material treatment	zwischenstufenverguetet 375 ... 475 HV 5		Blechedicke/ Mat.Thickn. DIN EN 10 140 0.6
Werkstoff/ Material	C 67 S DIN EN 10 132-4		Mat.-Code 1000
Benennung/ Partname <b>Mehrbereichssteckmutter</b> fuer Gewinde EN ISO 1478-ST-4.2, selbstsichernd			
Teil-Nr. / Part-No.	014519 001		C